



SCOTT CANOES

- BY -

abitibi & co.

LIVE BEYOND THE BEND

EDITION
2015



SCOTT CANOES

Every experienced paddler knows the feeling.

That desire to launch forth yet again: for greater adventure, new memories, the rush of the here and now. It's the knowledge that anything could happen, that a world of wonder awaits. Above all, it's the desire to find a waterway more challenging, more exciting than the last. To return home jubilant, filled with awe and thanks, and with the unceasing urge to get back out and do it all over again.

Scott canoes were born of this passion for paddling.

Since our early days building plywood canoes to navigate the pristine lakes and rivers of Ontario's Algonquin Park, we've been working to build better canoes, and to get more people in the water. Taking our community's desires and input to heart, we are constantly innovating and diversifying. After all, we want everyone from the youngest novice to the most experienced tripper to embrace the call of the water.

With a vast range of models, sizes, designs and colours to choose from, our goal is to help you find the canoe that will carry you through decades of adventure, and help you share your love of the wilderness with generations to come.

CONSTRUCTION

As it's our love for the wilderness that keeps us going, it only makes sense that we manufacture our products in a way that's environmentally sustainable. We construct our canoes with the best quality local materials, not just supporting the Canadian economy, but also reducing our footprint on the environment by saving fuel due to transportation. We also use state of the art technology that enables us to create the thinnest, strongest, hardest canoes possible, so you can spend more time seeking adventure and less time worrying about wear and tear. We're a proudly Canadian company with a promise to do everything we can to save our pristine natural environment for future generations. So when you buy a Scott canoe from Abitibi & co., know that it's not just quality you're investing in, but also the commitment to protect and restore our waterways, and help share this natural wonder with all Canadians.

Different environments: different paddlers. There's no one-size fits all canoe, although we do make a number of canoes that would keep most people pretty darn happy. Because we know that there are different styles of paddling, different environments and different reasons to be on the water, we have canoes to fit all personalities, waterways and trip durations. Built to last for decades, our canoes contain only the highest quality materials, and are created with a pride of workmanship that's kept us going for half a century.

Our canoes are constructed from fiberglass and Kevlar, composite materials that combine light weight, durability and performance. They're also easy to repair, so if you do have a run in with a rock, it won't be the end of the world (or your canoe). When we fabricate our canoes, we consider the combination of weight, strength and cost. Lighter canoes are generally easier to transport and manoeuvre. Our heavier models have thicker layers of lamination which increases durability, but also impacts weight. These considerations, and more, are incorporated into all of our designs so that you can feel confident that when you choose a Scott Canoe, it's the right one for you.

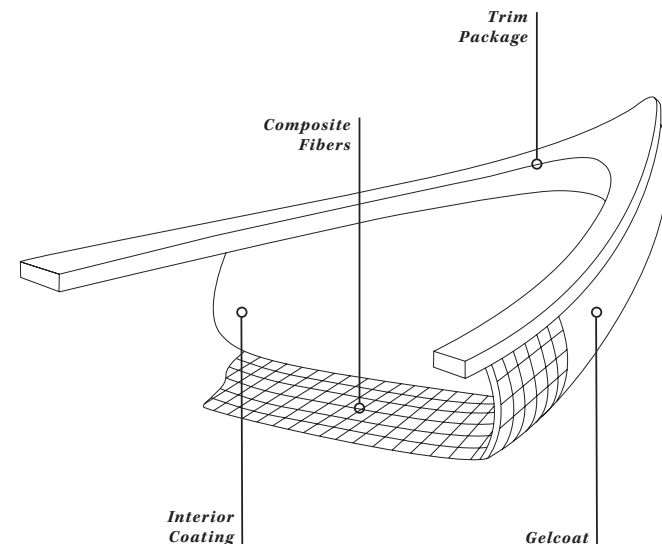

NEW FEATURE: KEEL STRIP
 We are always looking for ways to increase the durability and the quality of our canoes. This is why we've added a keel strip on both ends of every canoe.



FIBERGLASS

We have a soft spot for fiberglass canoes. Though they're slightly heavier than Kevlar laminate, they are extremely durable, and the most economical choice. We've been producing fiberglass canoes since 1965, so we've certainly had time to refine and improve on our designs and processes.

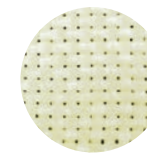

STANDARD KEVLAR

If weight's an issue, then Kevlar is definitely the way to go. This is our most popular laminate, and for good reason. Like our fiberglass canoes, the hull is rigid with a gentle flex. Both durable and lightweight, it's a fantastic choice for gung-ho trippers and idle paddlers alike.

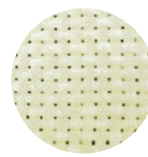

EXPEDITION KEVLAR

The sturdiest of our laminates, these canoes are durable in harsh conditions and with continual use. They can take a beating and yet survive soundly – ideal for extended white water use. Built from similar materials to the Standard Kevlar canoes but with extra layers added, Expedition Kevlar is popular among wilderness trippers and those who need extreme durability in a lightweight canoe.

HELPFUL INFORMATION

—
**WANT TO BUY
 A CANOE, BUT DON'T
 KNOW WHERE TO START?
 HERE'S A LIST
 OF PADDLING TERMS
 TO GET YOU GOING.**
 —

EFFICIENCY

-
 This is the measurement of the amount of effort it takes to paddle a canoe from point A to point B. Easy going? That canoe is efficient!

TRACKING

-
 Can you walk in a straight line? Even if you can't, you'll certainly want your canoe to be able to hold its course. A canoe that stays on course with little correction from a paddler is known to have good tracking. On the flipside, if a canoe can't keep straight without lots of corrective strokes, then it has poor tracking.

LOAD CAPACITY

-
 Straightforward and extremely important to remember: load capacity is the amount of weight a canoe can safely carry. And all savvy adventurers know that safety is key!

MANOEUVRABILITY

-
 Just like with people, machines and shopping carts, the manoeuvrability of a canoe describes how easy (or difficult!) it is to turn. The easier it is to control and change direction, the more manoeuvrable it is.

INITIAL STABILITY

-
 Hard time climbing into that canoe? Not much initial stability then. The initial stability of a vessel describes how much it wobbles or reacts to weight shifts. The more stable it feels, the more initial stability it has.

SEAWORTHINESS

-
 Not all canoes are created equal. A seaworthy canoe must be able to manoeuvre and make headway in windy, turbulent conditions. This doesn't just mean on the ocean – big lakes can be awfully choppy at times!

FINAL STABILITY

-
 This is how well a canoe resists tipping once it's loaded up and on the move. The more resistant it is to tipping when it's leaned to one side, the greater the final stability.

HULL SHAPE

-
 The shape of the canoe determines how efficiently it glides through water. While shallow arch and shallow V-shaped hulls may shoot more effectively through the water, flat bottomed canoes are far more stable.

BEAM

-
 The width at centre from gunwale to gunwale, or translated into non-paddler speak, it's the measurement of the widest point of the boat from edge to edge. If a canoe has a wide beam, it'll be more stable, seaworthy and have a large volume.

ROCKER

-
 Not describing your grandma favourite item of furniture, nor the guy still wearing leather pants. In the watersport world, rocker describes the curvature of the boat from end to end. The more rocker (curve), the more manoeuvrable it'll be. On the other hand, if a canoe has a straight keel line – that is, little or no rocker – it will have great tracking but less manoeuvrability.

OVERALL LENGTH

-
 The measurement from the stern tip to bow tip. The longer the canoe, the greater its capacity.

SIDE SHAPES

-
 Sides that widen or flare above the waterline tend to be more stable and seaworthy. That said, some prefer “tumblehome” sides, as they give you more access to the water. Tumblehome sides widen up above the waterline and then tuck back in toward the gunwales, but are more likely to tip if heeled dramatically.

CHINE

-
 Think of a teacup. Some are more rounded, while others more angular. With canoes, it's the same. The chine of a canoe refers to the transition from the bottom to the side: a soft chine refers to a gradual, more rounded transition. A hard chine is a straighter line with little rounding.

WATERLINE LENGTH

-
 This measures the length of the canoe at the four inch waterline. The longer the waterline length, the greater the planing surface, the more efficient the canoe.

WATERLINE WIDTH

-
 This measures the width of the canoe at the four inch waterline. The narrower the waterline width, the more efficient it is. But a wider waterline width means greater initial stability.

CANOE STYLES

There are two common styles that our canoes take.

Symmetrical

A more traditional symmetrical canoe has the same shape from the centre forward to the bow as they do from the centre back to the stern. With an even and predictable feel, they're the ideal choice for pleasure paddlers and newbies.

Asymmetrical

Asymmetrical canoes have sharper, sleeker bows with increased rocker. The sterns are shorter and ride deeper in the water. Quick, but with less initial stability than symmetrical canoes, these are great for more skilled paddlers.

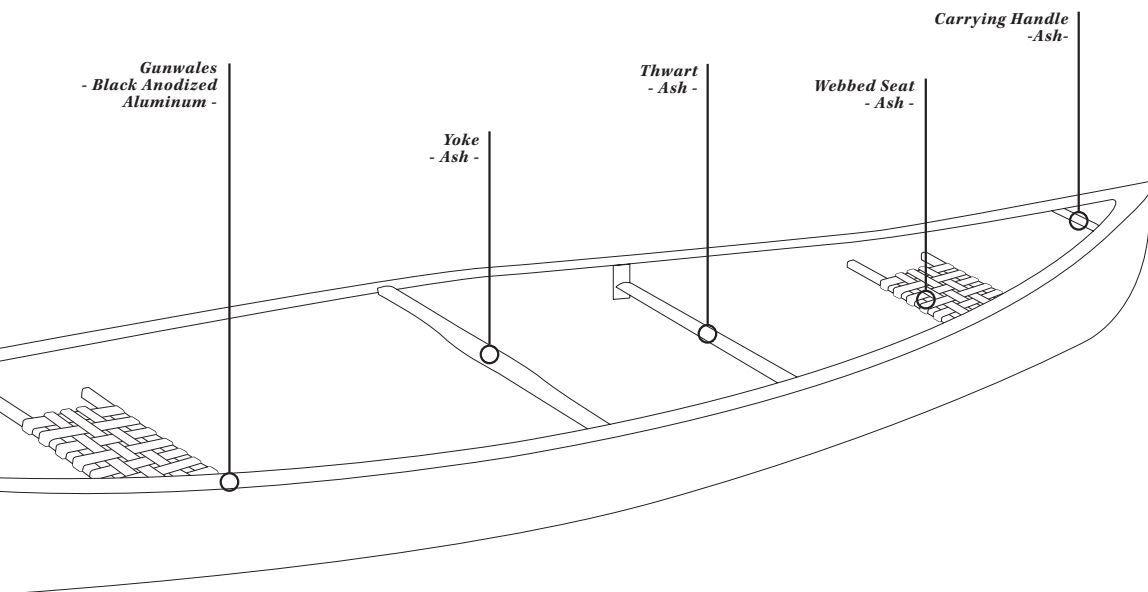

RECREATIONAL CANOES

Spend endless days splashing around in the lake, watching the sunset after dinner, drifting quietly in the twilight as you listen for the call of the loons. Take a daytrip to a nearby pond for fishing, hoping to catch your dinner, but content to simply be out there in the quiet. Our recreational canoes are a must-have for any cottage or day-tripping nature lover. They're easy to paddle and incredibly stable: ideal for newbies, but still great fun for expert trippers.

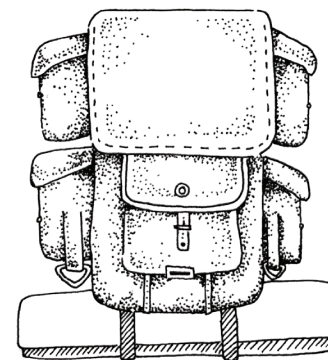

10

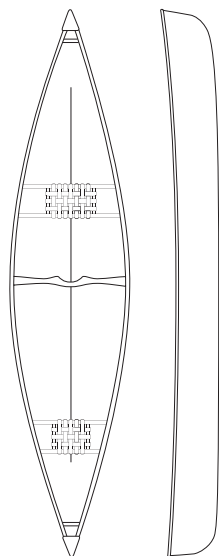

ECHO 14

Hit the road, the canoe strapped to the roof. Drive until you're deep in the woods, then set off for a hike to the lake you can never approach without a deep breath and a smile. Whether it's a weekend portaging trip or an early morning paddle around the lake, you'll be impressed by the responsiveness of the Echo 14. One of our more contemporary designs, it has a small added keel to reduce drift in windy conditions. For portaging, the Echo's Kevlar laminate is a fantastic choice. If you're launching from the dock, you'll never be disappointed by the Echo.

OVERALL		WEIGHT	
LENGTH	14"	FIBERGLASS	50 LB
GUNWALE WIDTH	35"	KEVLAR	44 LB
4" WATERLINE WIDTH	33.75"	EXPEDITION	53 LB
DEPTH AT CENTRE	13.25"		
BOW HEIGHT	20"		
STERN HEIGHT	20"		
CAPACITY FREEBOARD	650 LB		

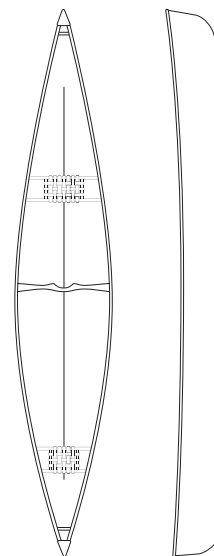

ECHO 16

It's mid afternoon and you've been drifting, binoculars in hand, your heart and mind filled with the sounds and sights of the open water. Turning for home, you paddle with ease, shooting ahead with each stroke, your cottage now in sight. This durable, nimble canoe is exceptionally fast for its size. The extra sharp entry lines and near vertical bow and stern make for outstanding tracking. The Echo design cruises with ease reminiscent of a much larger canoe. Perfect for day tours or short overnights.

OVERALL		WEIGHT	
LENGTH	16"	FIBERGLASS	55 LB
GUNWALE WIDTH	36"	KEVLAR	47 LB
4" WATERLINE WIDTH	34.5"	EXPEDITION	56 LB
DEPTH AT CENTRE	13.5"		
BOW HEIGHT	21"		
STERN HEIGHT	21"		
CAPACITY FREEBOARD	750 LBS		

11

WILDERNESS TRIPPING

Absolute freedom. The liberation you feel when your pack is safely stowed, your heart in your throat. You're about to set off for days, for weeks, even. You paddle the same routes as the earliest inhabitants of this land, and following their example, simply witnessing the glory of the gnarly trees, the unending starry skies, the rugged beauty of the cliffs and firs. Our tripping canoes are based on those used by the First Nations of Canada. Fantastic for hunting and fishing, these highly versatile and responsive canoes can take you anywhere you want to go. For the expert paddler, they excel under extreme loads and extreme conditions, performing superbly in flat water, white water, high wind and waves. Less experienced paddlers will appreciate the high level of stability, even under very heavy loads.

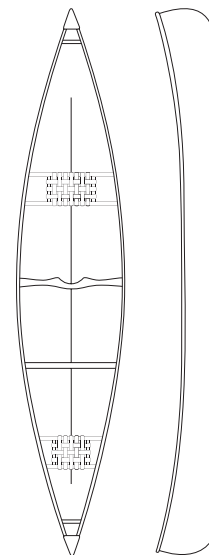

PROSPECTOR 16

You have your plan. You have your map. Your packs are on your backs and ambition is sky high. A new challenge: a new experience. It's just you and the elements, and you know it'll all be worth it. The first choice of experienced wilderness paddlers, the Prospector 16 is perfect for rough waters and heavy loads and is fantastically manoeuvrable. An easy ride for both the novice and experienced paddler, this is a true expedition canoe that can handle anything the wilderness can dish out.

OVERALL		WEIGHT	
LENGTH	16"	FIBERGLASS	62 LB
GUNWALE WIDTH	36"	KEVLAR	52 LB
4" WATERLINE WIDTH	32.25"	EXPEDITION	54 LB
DEPTH AT CENTRE	14"		
BOW HEIGHT	21.5"		
STERN HEIGHT	21.5"		
CAPACITY FREEBOARD	940 LB		

12

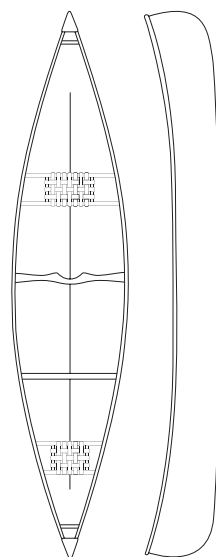

PROSPECTOR 15

A week of camping: the sandy beach just down the way. Long days spent exploring the tiny islands that dot the lake. You're feeling ambitious, so you pack up your gear, portage the well-trodden paths and find the next spot. In the Prospector 15 you can do anything, go anywhere. With one of the most versatile classic hull designs available, this canoe can be paddled solo or tandem. With stability, speed and manoeuvrability in all water conditions, when it comes to day tripping, this is a canoe you'll never grow out of.

OVERALL		WEIGHT	
LENGTH	15.2"	FIBERGLASS	60 LB
GUNWALE WIDTH	36"	KEVLAR	50 LB
4" WATERLINE WIDTH	32.75"	EXPEDITION	52 LB
DEPTH AT CENTRE	14"		
BOW HEIGHT	21.5"		
STERN HEIGHT	21.5"		
CAPACITY FREEBOARD	760 LB		

13

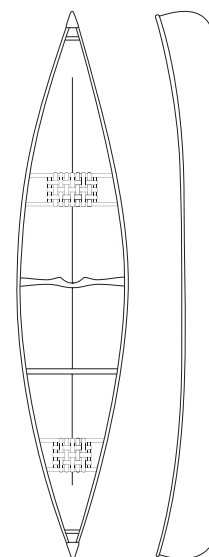

PROSPECTOR 17

Sometimes what makes the perfect trip is the perfect partner. You glide effortlessly through the water, strokes in synch, lapping up the beauty of the day. In this ideal tandem canoe for wilderness day tripping, you can manoeuvre easily through rough waters even with heavy loads. Its large carrying capacity makes it a great fit for family camping trips. A true performer in the roughest conditions, this canoe will never let you down.

OVERALL		WEIGHT	
LENGTH	16'10"	FIBERGLASS	69 LB
GUNWALE WIDTH	36"	KEVLAR	57 LB
4" WATERLINE WIDTH	33"	EXPEDITION	59 LB
DEPTH AT CENTRE	14"		
BOW HEIGHT	21"		
STERN HEIGHT	19"		
CAPACITY FREEBOARD	970 LB		

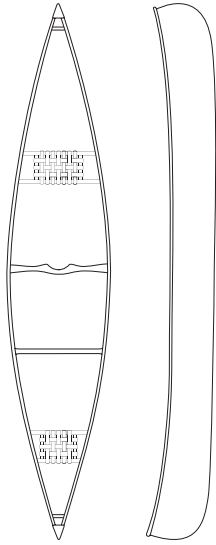

RIVER DANCER

You glide through the rushing water, hurtling past rocky outcrops, sandy beaches, twisting and turning with the flow, allowing the river to guide you to your next destination. This beauty of a canoe is exceptionally well balanced, and ready to carry you to wherever your next adventure leads. The V hull design makes for good tracking and stability and it sheds waves for a dry ride when you need it. It also handles easily, granting you the confidence to take the River Dancer anywhere you choose to go.

OVERALL

LENGTH	16"
GUNWALE WIDTH	36"
4" WATERLINE WIDTH	32.75"
DEPTH AT CENTRE	14"
BOW HEIGHT	21.5"
STERN HEIGHT	21.5"
CAPACITY FREEBOARD	940 LB

WEIGHT

FIBERGLASS	62 LB
KEVLAR	52 LB
EXPEDITION	54 LB



14

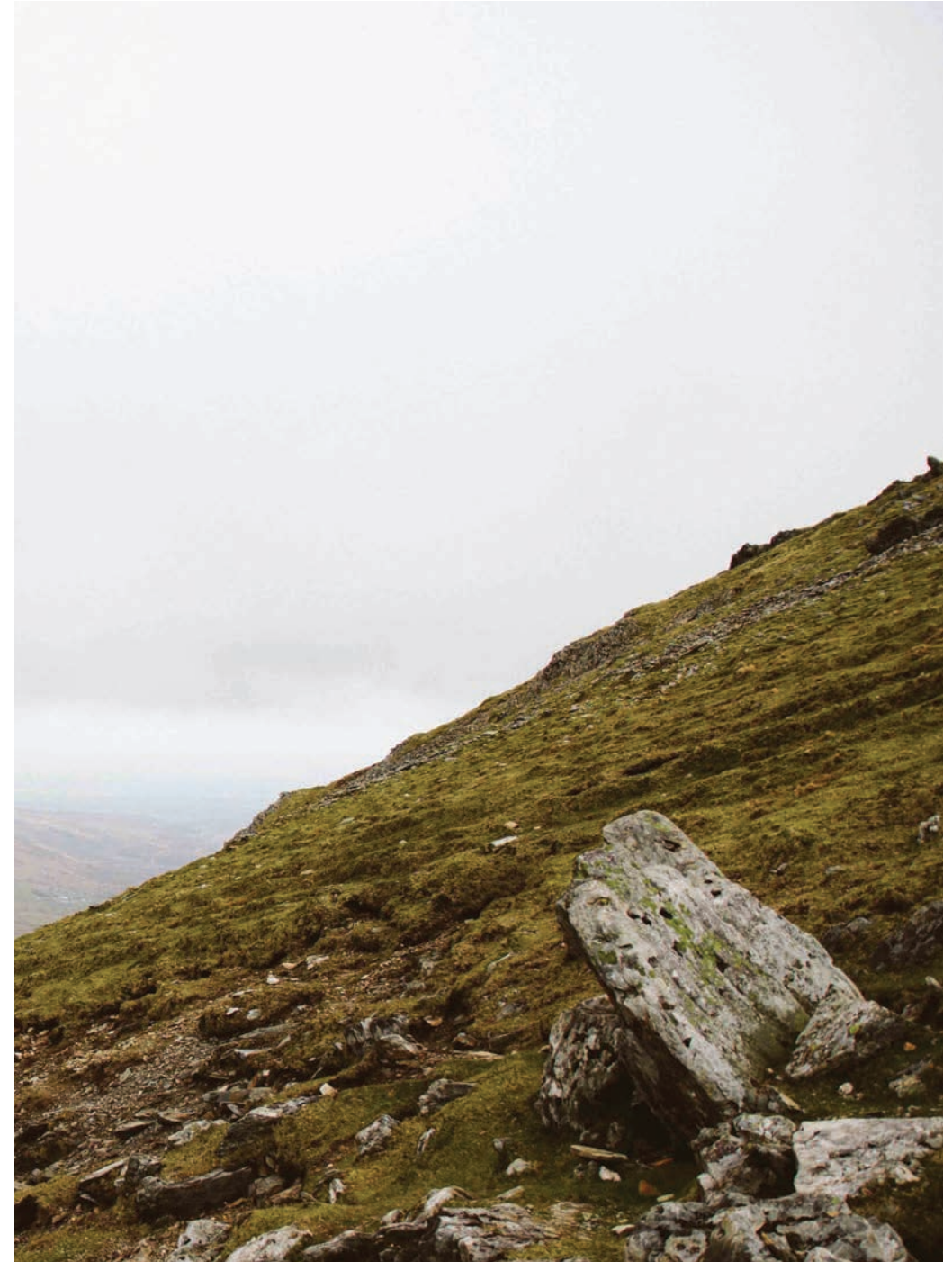

15

SCOTT CLASSIC CANOE SERIES

In 1965, when the very first Scott canoes were put on the market, the Wilderness became an instant classic. With excellent performance for a boat with amazing initial and final stability. Wilderness travellers found that they could carry very large loads without sacrificing speed or manoeuvrability. Novice paddlers were pleasantly surprised by the craft's uncanny ability to inspire confidence. Over the years, Scott canoe developed a series of models inspired by the classic design of the Wilderness. With a unique blend of efficiency, manoeuvrability and stability, there's a reason why these canoes have become classics.

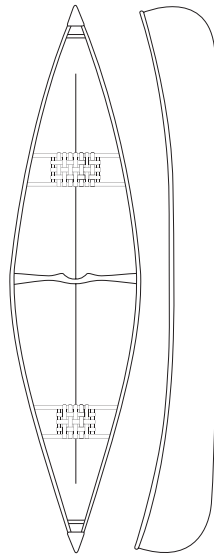

L'IL CANOE

Her brow furrowed as she concentrates on pushing the paddle through the water, your heart bursting with joy as you share your love for the lake. This wonderful little canoe for kids and adults has remarkable initial stability for the size and is easily manoeuvrable even for the littlest paddlers. Solo paddlers are often pleasantly surprised by how well it performs, even in choppy water. When winter comes, the L'il Canoe's size means you can easily store it inside the cottage.

OVERALL		WEIGHT	
LENGTH	12"	FIBERGLASS	46 LB
GUNWALE WIDTH	34"	KEVLAR	40 LB
4" WATERLINE WIDTH	33"	EXPEDITION	N/A
DEPTH AT CENTRE	12"		
BOW HEIGHT	19.75"		
STERN HEIGHT	19.75"		
CAPACITY FREEBOARD	450 LB		

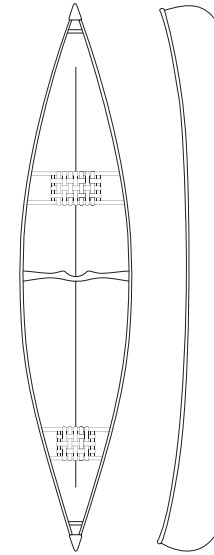

EXPLORER

This small responsive hull is ideal for the camp or cabin. By design it is easy turning with loads of initial stability, granting ideal performance in less than ideal conditions. Children have a ball in this user friendly package and adults will find it perfect for an evening of fishing or a casual paddle while sightseeing. You can't beat the Explorer for discovering meandering creeks and small lakes.

OVERALL		WEIGHT	
LENGTH	14"	FIBERGLASS	56 LB
GUNWALE WIDTH	35"	KEVLAR	47 LB
4" WATERLINE WIDTH	33"	EXPEDITION	N/A
DEPTH AT CENTRE	13.5"		
BOW HEIGHT	20.5"		
STERN HEIGHT	20.5"		
CAPACITY FREEBOARD	665 LB		

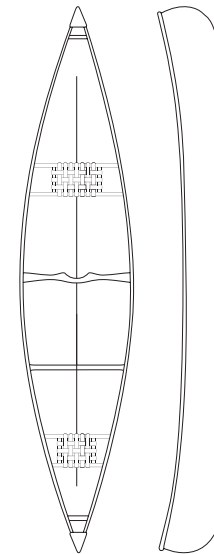

WILDERNESS

Splashing, shrieking, sun-drenched, don't want to leave the water for days on end. Let's explore the lake! Can I come too? For anyone who wants to experience the water, this casual paddling canoe is our number one seller. For day paddlers looking for a relaxing, secure-feeling craft, the Wilderness will inspire confidence. It's been a favourite with beginners and expert paddlers since its introduction fifty years ago. This canoe is awesome because it's just plain fun.

OVERALL		WEIGHT	
LENGTH	15.2"	FIBERGLASS	60 LB
GUNWALE WIDTH	36"	KEVLAR	50 LB
4" WATERLINE WIDTH	33.5"	EXPEDITION	N/A
DEPTH AT CENTRE	14"		
BOW HEIGHT	21"		
STERN HEIGHT	21"		
CAPACITY FREEBOARD	760 LB		

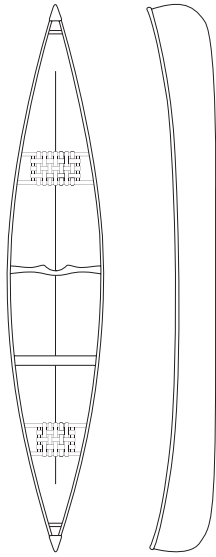

TRIPPER

This highly capable hull excels to carry family and gear with ease, on a casual afternoon paddle or an extended wilderness outing. It's a stable, secure, high volume canoe with excellent paddling performance even when heavily loaded. For tandem use on fast moving rivers or placid lakes. Another all-around big volume boat.

OVERALL

LENGHT	16"
GUNWALE WIDTH	36"
4" WATERLINE WIDTH	34.5"
DEPTH AT CENTRE	14"
BOW HEIGHT	22"
STERN HEIGHT	22"
CAPACITY FREEBOARD	541 LB

WEIGHT

FIBERGLASS	62 LB
KEVLAR	52 LB
EXPEDITION	55 LB

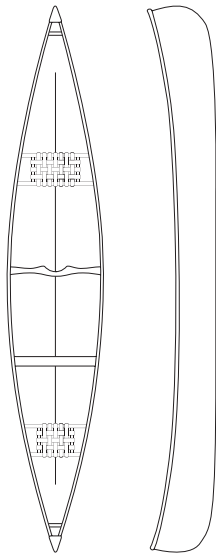

ADVENTURER

Drops of rain splash in concentric circles on the windblown water. Your son is huddled in front of you, his chin resting on your pack, his eyes wide as he watches the ominous sky. You signal to your wife that it's time to make camp, and you paddle swiftly to the sandy bank. The proficient paddler will love the Adventurer's high volume hull that paddles gracefully even under a heavy load. The ideal choice for families that need extra space: you can carry all the gear needed for the extended wilderness adventure you've been dreaming of. It's also forgiving; simply a pleasure to paddle.

OVERALL

LENGHT	17"
GUNWALE WIDTH	36"
4" WATERLINE WIDTH	34"
DEPTH AT CENTRE	15"
BOW HEIGHT	22.5"
STERN HEIGHT	22.5"
CAPACITY FREEBOARD	101.5 LB

WEIGHT

FIBERGLASS	66 LB
KEVLAR	55 LB
EXPEDITION	57 LB

LIVE
beyond
The
BEND

SPORTING CANOES AND DUCK BOATS

Rod and tackle, PFD, sandwiches for lunch and a couple of beers. You're set for a day on the water, and all you need is to get there, and fast.

If you're the sporting type with a goal in mind, you'll fall in love with our sporting canoes and duck boats. Built for stability and durability, you'll be shooting through the water and reeling them in in no time.

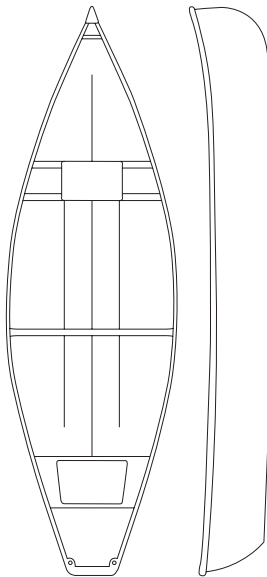

FEATHER

Drift in the misty morning, your rod in hand, hot thermos at your side. Your cooler just waiting to be filled, you're at your favourite spot and filled with anticipation. The 12' Feather is an original Scott design. Created for the outdoor enthusiast who wants a small lightweight craft, this canoe can be easily portaged and propelled by a small outboard motor. (We suggest a one or two horsepower motor). For stability, we've built it extra wide. Always a dry ride to your favourite pond.

OVERALL

LENGHT	11'4"
GUNWALE WIDTH	44"
TRANSOM WIDTH	12"
4" WATERLINE WIDTH	39"
DEPTH AT CENTRE	13"
BOW HEIGHT	19.75"
STERN HEIGHT	16"
CAPACITY FREEBOARD	673 LB

WEIGHT

FIBERGLASS	57 LB
KEVLAR	50 LB

20

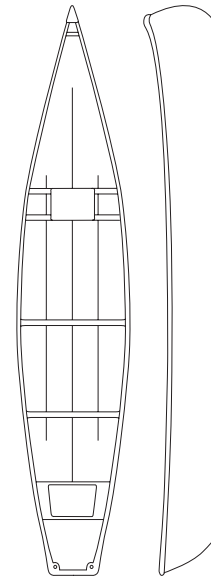

BUSHMAN

The line goes taut and you're surprised by the weight. Catching a glimpse of the slick, shimmering beast, you pray that the line doesn't snap. Time expands and it's just you and the fish: you're hoping to tire it out, can't wait to take home your prize. Your ambitions too big for the pond, you want to explore new spots and need a boat that can take you there. Clamp on a four horsepower motor and you'll be speeding to supper in no time. Though it's shorter than the Woodsman, the Bushman was designed for higher volume, so it's ideal for those who want to carry a little more gear. Though it's shorter than the Woodsman, the Bushman was designed for higher volume, so it's ideal for those who want to carry a little more gear.

OVERALL

LENGHT	14'2"
GUNWALE WIDTH	36"
TRANSOM WIDTH	18"
4" WATERLINE WIDTH	36"
DEPTH AT CENTRE	15"
BOW HEIGHT	22.75"
STERN HEIGHT	18"
CAPACITY FREEBOARD	915 LB

WEIGHT

FIBERGLASS	85 LB
KEVLAR	70 LB

21

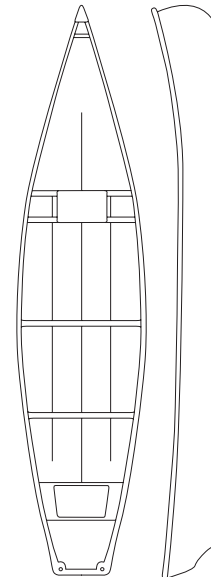

WOODSMAN

You all pile into the boat, cooler loaded with lunch, fishing nets, balls and bats. You glide across the water, your destination the remote beach, laughter trailing behind you, wind in your face. For fishing or as a small runabout, the Woodsman is a slender and sleek y-stern which is easy to paddle, or to propel with a small motor. Ideal for families, this canoes will be your ticket to any water activity you can dream of.

OVERALL

LENGHT	15"
GUNWALE WIDTH	36"
TRANSOM WIDTH	15"
4" WATERLINE WIDTH	35"
DEPTH AT CENTRE	14"
BOW HEIGHT	22.5"
STERN HEIGHT	16.5"
CAPACITY FREEBOARD	833 LB

WEIGHT

FIBERGLASS	85 LB
KEVLAR	70 LB

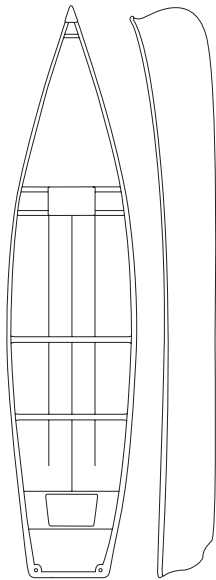

MAKOBÉ

You're five in the boat and your youngest leans her head over the side, watching the water rush by as you're propelled to your destination. Tail wagging, Buddy leaps into the water, as you cut the motor and paddle toward the beach. Fishing, hunting, cavorting, exploring: you're going camping, and you're going to do it right. For remote fishing and hunting trips, this 16' large load capacity canoe gives you the stable ride of a small boat. Propelled with a four or six horsepower motor it'll get you and everything you need to where you want to be. The perfect family boat.

OVERALL		WEIGHT	
LENGHT	15'8"	FIBERGLASS	100 LB
GUNWALE WIDTH	42"	KEVLAR	85 LB
TRANSOM WIDTH	25"		
4" WATERLINE WIDTH	38"		
DEPTH AT CENTRE	17"		
BOW HEIGHT	27"		
STERN HEIGHT	17"		
CAPACITY FREEBOARD	1147 LB		

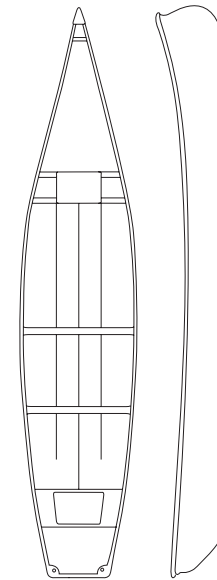

ALBANY AND HUDSON BAY FREIGHTER

The sun hangs low above the horizon, as you turn for home, your boat low in the water with the added weight of your prize. For hunting expeditions, the 21' Hudson Bay and the 18' Albany will carry you, your partner and a couple moose if you're having a lucky day. Both canoes need larger motors to push increased loads: we recommend a nine horsepower motor for the Albany and a 20 for the Hudson Bay. The standard construction features include: heavy-duty laminates, triple keel with aluminum pipe reinforcing, minimum of eight beefy cross ribs, cast aluminum nose and corner caps with built-in handles, extra wide ash gunwales and thwarts. The stern seat is made of solid wood and covered in fiberglass with flotation materials within. The 21' Hudson Bay comes standard with a solid center seat of the same construction.

ALBANY

OVERALL		WEIGHT	
LENGHT	18'4"	FIBERGLASS	185 LB
GUNWALE WIDTH	50"	KEVLAR	REQUEST
TRANSOM WIDTH	26"		
4" WATERLINE WIDTH	41"		
DEPTH AT CENTRE	18"		
BOW HEIGHT	29"		
STERN HEIGHT	20"		
CAPACITY FREEBOARD	1555 LB		

HUDSON BAY FREIGHTER

OVERALL		WEIGHT	
LENGHT	21"	FIBERGLASS	250 LB
GUNWALE WIDTH	56"	KEVLAR	REQUEST
TRANSOM WIDTH	26"		
4" WATERLINE WIDTH	47"		
DEPTH AT CENTRE	20"		
BOW HEIGHT	34"		
STERN HEIGHT	22.5"		
CAPACITY FREEBOARD	2000 LB		



DUCKBOATS

A splash in the water and your retriever hurls himself ahead, yelping as he moves, his tail like a flag, eyes on the prize. He swims back to you and scrambles up into the boat, covering you with water, but successful and proud. This class of specialized boats is in a league of their own. The unique stabilizing chines that protrude at the waterline make these boats so stable that your retrievers can climb on board directly from the water, and hardly even tip the boat. These make excellent fishing and hunting boats, and they can be towed or mounted on a car. A more stable boat you're not likely to find.

12' DUCKBOAT

OVERALL		WEIGHT	
LENGTH	12"	FIBERGLASS	102 LB
GUNWALE WIDTH	40"	KEVLAR	92 LB
4" WATERLINE WIDTH	43"		
DEPTH AT CENTRE	12.5"		
BOW HEIGHT	18"		
STERN HEIGHT	15"		
CAPACITY FREEBOARD	2 PEOPLE		



14' DUCKBOAT

OVERALL		WEIGHT	
LENGTH	14"	FIBERGLASS	115 LB
GUNWALE WIDTH	41"	KEVLAR	105 LB
4" WATERLINE WIDTH	44"		
DEPTH AT CENTRE	14"		
BOW HEIGHT	20"		
STERN HEIGHT	15"		
CAPACITY FREEBOARD	3 PEOPLE		



24

14' DEEP DUCKBOAT

OVERALL		WEIGHT	
LENGTH	14"	FIBERGLASS	120 LB
GUNWALE WIDTH	41"	KEVLAR	110 LB
4" WATERLINE WIDTH	44"		
DEPTH AT CENTRE	16"		
BOW HEIGHT	22"		
STERN HEIGHT	15"		
CAPACITY FREEBOARD	3 PEOPLE		



16' DEEP DUCKBOAT

OVERALL		WEIGHT	
LENGTH	16'2"	FIBERGLASS	190 LB
GUNWALE WIDTH	53"	KEVLAR	170 LB
4" WATERLINE WIDTH	48"		
DEPTH AT CENTRE	19"		
BOW HEIGHT	23"		
STERN HEIGHT	17"		
CAPACITY FREEBOARD	1200 LB		



25

	LENGTH	GUNWALE WIDTH	4" WATERLINE WIDTH	DEPTH AT CENTRE	BOW HEIGHT	STERN HEIGHT	CAPACITY 6" FREEBOARD	WEIGHT FIBERGLASS	WEIGHT KEVLAR	WEIGHT EXPEDITION	HULL CONFIGURATION
RECREATIONAL CANOES							(LBS)	AVERAGE FINISHED WEIGHTS (LBS)			
ECHO 14	14"	35"	33.75"	13.25"	20"	20"	650 lb	50 lb	44 lb	53 lb	Slight Rocker, Symmetrical Shallow Arch, Flared Sides, Small Keel
ECHO 16	16"	36"	34.5"	13.5"	21"	21"	750 lb	55 lb	47 lb	56 lb	"
WILDERNESS TRIPPING											
PROSPECTOR 15	15'2"	36"	32.75"	14"	21.5"	21.5"	760 lb	60 lb	50 lb	52 lb	Slight Rocker, Symmetrical, Shallow Arch, Tumblehome, Shoe Keel
PROSPECTOR 16	16"	36"	32.25"	14"	21.5"	21.5"	940 lb	62 lb	52 lb	54 lb	"
PROSPECTOR 17	16'10"	36"	33"	14"	21"	19"	970 lb	69 lb	57 lb	59 lb	"
RIVER DANCER	16"	36"	32.75"	14"	21.5"	21.5"	940 lb	62 lb	52 lb	54 lb	Moderate Rocker, Symmetrical, Shallow V, Tumblehome, Keelless
SCOTT CLASSIC CANOE SERIES											
L'IL CANOE	12"	34"	33"	12"	19.75"	19.75"	450 lb	46 lb	40 lb	N/A	Slight Rocker, Symmetrical, Relatively Flat Bottom, Tumblehome, Keel
EXPLORER	14"	35"	33"	13.5"	20.5"	20.5"	665 lb	56 lb	47 lb	N/A	"
WILDERNESS	15.2"	36"	33.5"	14"	21"	21"	760 lb	60 lb	50 lb	N/A	Slight Rocker, Symmetrical, Tumblehome, Keel
TRIPPER	16"	36"	34.5"	14"	22"	22"	941 lb	62 lb	52 lb	55 lb	"
ADVENTURER	17"	36"	34"	15"	22.5"	22.5"	101.5 lb	66 lb	55 lb	57 lb	Slight Rocker, Symmetrical, Relatively Flat Bottom, Tumblehome, Keel

WEIGHT INFORMATION

All published weights are based on an average weight, which is calculated by weighing many completed canoes of the same model and trim. Published weights and specifications may vary. Abitibi & co. reserves the right to alter the specifications and construction in a continuing product improvement policy.

A ASYMMETRICAL
S SYMMETRICAL

* **THIS IS OPTIMUM, NOT MAXIMUM OR LOADED TO THE GUNWALES CAPACITY**

	LENGTH	GUNWALE WIDTH	TRANSOM WIDTH	4" WATERLINE WIDTH	DEPTH AT CENTRE	BOW HEIGHT	STERN HEIGHT	CAPACITY 6" FREEBOARD	WEIGHT FIBERGLASS	WEIGHT KEVLAR	HULL CONFIGURATION
SPORTING CANOES AND DUCK BOATS									AVERAGE FINISHED WEIGHTS (LBS)		
FEATHER	11.4"	44"	12"	39"	13"	19.75"	16"	673 lb	57 lb	50 lb	Moderate Rocker, Flat Bottom, Tumblehome, Triple Keel
BUSHMAN	14'2"	36"	18"	36"	15"	22.75"	18"	915 lb	85 lb	70 lb	Moderate Rocker, Flat Bottom, Straight Sides, Triple Keel
WOODSMAN	15"	36"	15"	35"	14"	22.5"	16.5"	833 lb	85 lb	70 lb	"
MAKOBE	15"	42"	25"	38"	17"	27"	17"	1147 lb	100 lb	85 lb	Moderate Rocker, Flat Bottom, Tumblehome, Triple Keel
ALBANY	18'4"	50"	26"	41"	18"	29"	20"	1555 lb	185 lb	Request	"
HUDSON BAY FREIGHTER	21"	56"	26"	47"	20"	34"	22.5"	2000 lb	250 lb	Request	"

WEIGHT INFORMATION

All published weights are based on an average weight, which is calculated by weighing many completed canoes of the same model and trim. Published weights and specifications may vary. abitibi & co. reserves the right to alter the specifications and construction in a continuing product improvement policy.

	LENGTH	GUNWALE WIDTH	4" WATERLINE WIDTH	DEPTH AT CENTRE	BOW HEIGHT	STERN HEIGHT	CAPACITY 6" FREEBOARD	WEIGHT FIBERGLASS	WEIGHT KEVLAR
DUCKBOATS								AVERAGE FINISHED WEIGHTS (LBS)	
12" DUCKBOAT	12"	40"	43"	12.5"	18"	15"	2 people	102 lb	92 lb
14" DUCKBOAT	14"	41"	44"	14"	20"	15"	3 people	115 lb	105 lb
14" DEEP DUCKBOAT	14"	41"	44"	16"	22"	15"	3 people	120 lb	110 lb
16" DEEP DUCKBOAT	16'2"	53"	48"	19"	23"	17"	1200 lb	190 lb	170 lb

A ASYMMETRICAL
S SYMMETRICAL

*** THIS IS OPTIMUM, NOT MAXIMUM OR LOADED TO THE GUNWALES CAPACITY**

ADD-ON OPTIONS

Trim

All of our wood trim is finished with an exterior grade easy-to-maintain oil-based product to ensure that the wood keeps a beautiful natural look for longer. You'll be able to enjoy your canoe for many years before it will need a little love to keep its natural beauty.

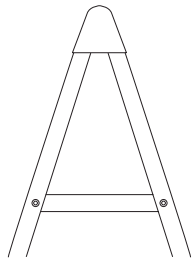

BLACK VINYL TRIM

This tough maintenance-free trim system is standard on all Scott canoes. The package comes with vinyl gunwales, ash webbed seats, ash handles, ash thwarts and an ash centre yoke and will take even the heaviest use.

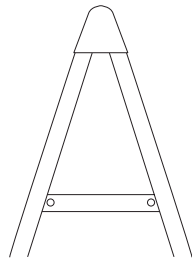

STANDARD ALUMINUM TRIM

This package is designed for outfitters. The gunwales are made of a tough satin finished aluminum. Handles, thwarts and nose caps are also aluminum. The seats are made of durable maintenance-free aluminum hangers and large seat plates that have been padded with closed cell ethafoam for comfort. This package is economical, extra tough and wonderfully maintenance free.

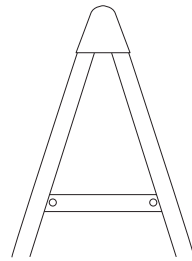

WOOD /ALUMINUM TRIM

This trim is available on most Scott canoes, and comes with ash webbed seats, ash handles, ash thwart and an ash centre yoke. All this supported by aluminum gunwales.

30

Colours

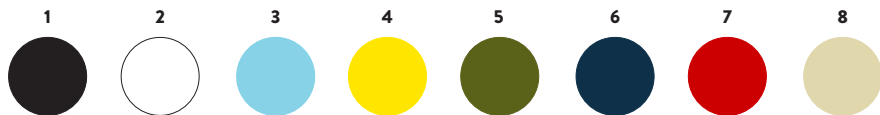

EDITION

CONTACT US
FOR MORE INFORMATION

INFO@ABITIBICO.CA
WWW.ABITIBICO.CA



abitibi & co.

LIVE BEYOND THE BEND

ABITIBICO.CA